

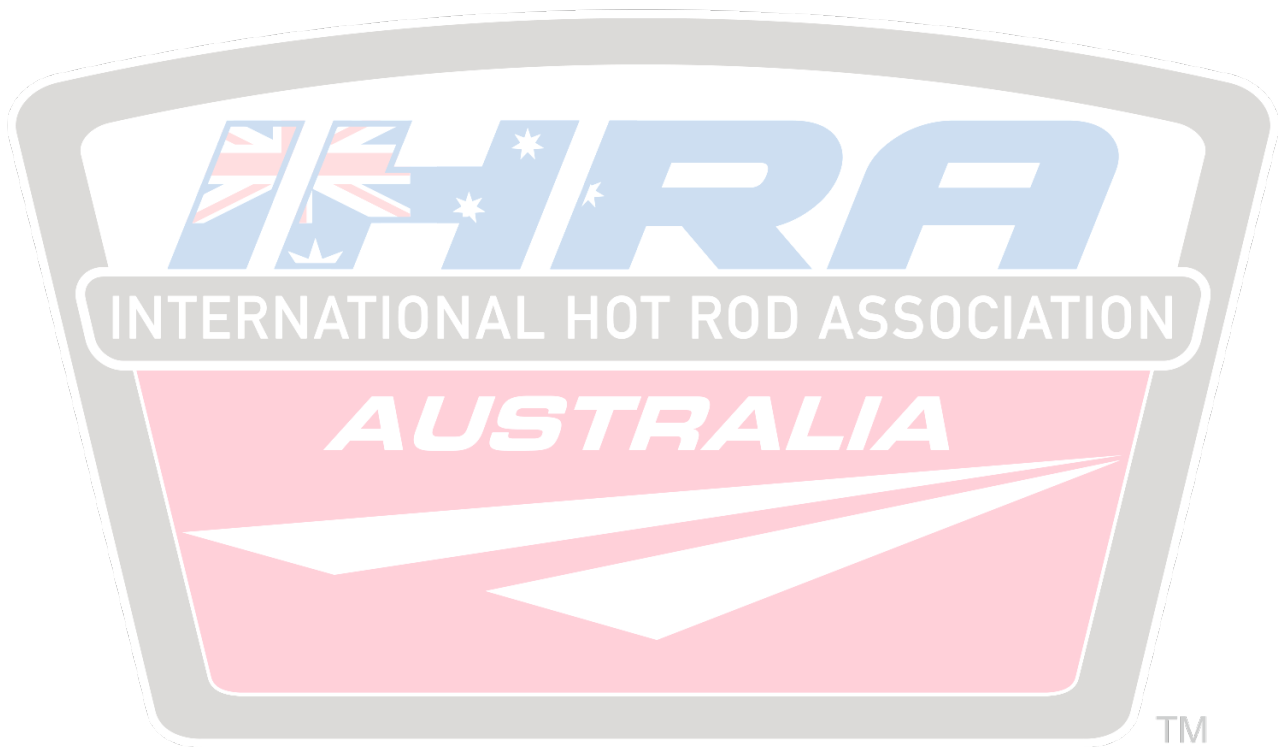

# **SEDAN ROLL CAGE REGULATIONS**

Version 1.0 26092017

NOTES:





# ROLL CAGE REGULATIONS

## NO ROLL CAGE REQUIRED

Vehicles that do not require a roll cage:

- a) Road registered open cars with an ET slower than 12.99 seconds, 1/4 mile
- b) Open competition cars with an ET slower than 10.50 seconds, 1/4 mile
- c) Unmodified cars with an ET slower than 10.50 seconds, 1/4 mile
- d) Modern Street cars with an ET slower than 10.00 seconds, 1/4 mile

## SINGLE ROLL OVER HOOP REQUIREMENT

Vehicles that require a single roll over hoop:

(May be welded or removable. Must have a side intrusion bar fitted on driver's-side.)

- a) Unmodified cars with an ET between 10.00 and 10.50 seconds, 1/4 mile
- b) Modified cars with an ET between 10.50 and 11.99 seconds, 1/4 mile
- c) Road registered open cars

## FOUR-POINT ROLL CAGE REQUIREMENT

Utilities may use a four-point welded roll cage design with removable side intrusion bars. Diagonal roof braces are mandatory on both sides of vehicle. Construction of four-point cages is to be based on design specifications equivalent to a six-point roll cage.

**NOTE:** All Utilities (ET 8.00 seconds 1/4 mile or slower)

*Removable four-point roll cage will be built to material specifications listed below for four-point and six-point roll cage. Removable roll cage will be constructed to removable roll cage specification. Welded four-point roll cage will be built to material specification listed for full six-point roll cage.*

## FULL SIX-POINT ROLL CAGE OF WELDED CONSTRUCTION

Sedans, and sedan-type vehicles with an ET quicker than 10.00 seconds 1/4 mile (or 1/8 mile equivalent) require a six-point roll cage permanently welded to the vehicle frame with either welded or removable side intrusion bars.

**NOTE:** Sedan-type vehicles that are constructed in such a way that the body could separate from the chassis/roll cage in an accident, require mesh or net (with a maximum of 3 inch (75mm) openings) to be fitted to the roll cage over the drivers head.

## FOUR-POINT ROLL CAGE REQUIREMENT

Utilities may use a four-point welded or removable roll cage design with side intrusion bars/mandatory to have diagonals on both sides of vehicle. Construction of four-point cages is to be based on design specifications equivalent to a six-point roll cage.

**NOTE:** All Utilities with an ET of 8.00 seconds (1/4 mile) or slower

*Removable four-point roll cage must be built to material specifications listed below for four-point and six-point roll cage. Removable roll cage will be constructed to removable roll cage specification. Welded four-point roll cage, will be built to material specification listed for full six-point roll cage.*

**NOTE:** It is recommended that vehicles with a performance of 8.00 seconds 1/4 mile or quicker are built to the applicable SFI Chassis Specification. To obtain SFI Chassis Specifications, Please contact Maurice Allen: Email [mallen@ihra.com](mailto:mallen@ihra.com)

# ROLL CAGE REGULATIONS

## WELDED ROLL CAGE MOUNTING POINTS

Minimum area of 60 sq. cm (9 sq. inch). May be shaped to suit floor pan of vehicle. Minimum width of 50mm in any single direction.

To be constructed of 3mm steel minimum, and welded to floor as well as to the main hoop or brace. Minimum weld bead of 3mm (1/8") required for full circumference of tube.

Must be located as close to sills or frame rails as practical.

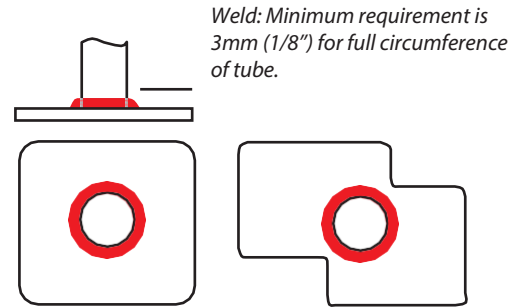

### Foot Plate Example

Surface area = 60 sq. cm (9 sq. inch)

## SIDE INTRUSION BARS

Must be mounted on the driver's side so that the rear attachment point is between the driver's shoulder and elbow.

Forward attachment point to be low enough to allow uninhibited entry and exit from the vehicle. If passenger is carried, a side intrusion bar is also required on that side of the vehicle.

## REMOVABLE SIDE INTRUSION BARS

Only permitted for vehicles with an ET slower than 8.00 seconds 1/4 mile (1/8 mile equivalent). Subject to periodic inspection.

## TAXI BAR WELDED OR REMOVABLE

Not to be mounted above, or more than 150mm (6 inch) below, driver's shoulders. To be attached to vehicle uprights, and positioned to support the seat.

**Note:** Support bracket may be attached to Taxi Bar to support the seat.

Removable Taxi Bar permitted but is subject to Approval from IHRA Australia Technical

## ROLL CAGE MOUNTING WELD-IN BUSH

### CRUSH TUBE

Required wherever roll cage mounting bolts pass through a hollow section of the vehicle's structure.

### ROLL CAGE MOUNTING WELD IN BUSH

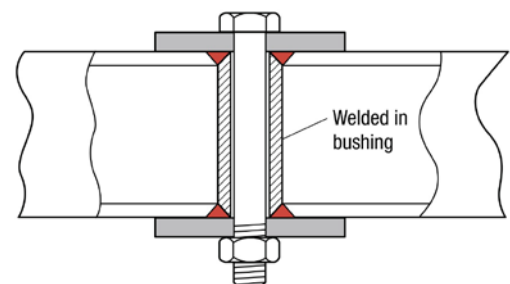

# ROLL CAGE REGULATIONS

## ROLLOVER PROTECTION HEAD CLEARANCE

A maximum of 150mm (6 inches) from the main hoop to rear of helmet must be observed. A maximum of 125mm (5 inches) must be maintained from the bottom of the main hoop to the top of the helmet.

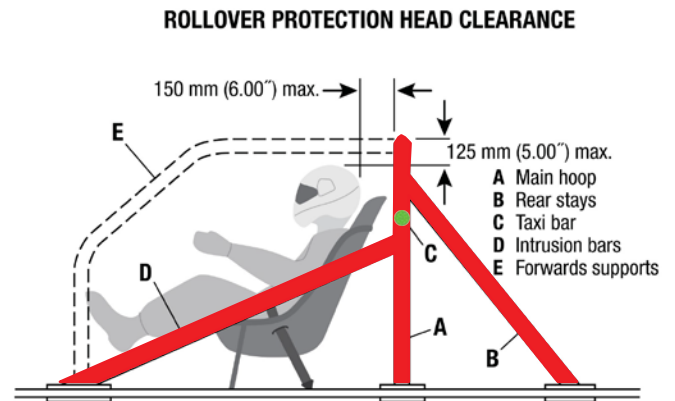

### General Reg 1240, Safety / Frame, Roll Cage, Main Hoop (Mandatory)

When the seat is at the end of its rear travel, no greater than 150 mm between the occupant's head and the hoop.

### General Reg 1250, Safety / Frame, Roll Cage, Main Hoop (Mandatory)

If a closed vehicle, main hoop to closely follow the shape of the interior.

### General Reg 1260, Safety / Frame, Roll Cage, Material (Mandatory)

Mild steel tubing rated to a yield strength of at least 350MPa.

### General Reg 1270, Safety / Frame, Roll Cage, Material (Mandatory)

Main cage members using circular hollow section (CHS)

### General Reg 1280, Safety / Frame, Roll Cage, Material (Mandatory)

If chassis rails, then rectangular hollow section (RHS)

### General Reg 1290, Safety / Frame, Roll Cage, Material (Forbidden)

If new roll cage or roll bar, then welded using electrical resistance welding.

### General Reg 1300, Safety / Frame, Roll Cage, Material (Mandatory)

If new roll cage or roll bar, then either cold drawn welded (CDW) mild steel, cold drawn seamless (CDS) mild steel or 4130 chrome-moly.

### General Reg 1310, Safety / Frame, Roll Cage, Material

Any vehicle under production prior to 31/12/2012 may apply to IHRA Technical for approval.

### General Reg 1360, Safety / Frame, Roll Cage, Mounting (Mandatory)

If mounting points and roll bar material have different strength, then reinforced with a steel plate with no less than 9 square inches of surface area.



# ROLL CAGE REGULATIONS

## General Reg 1370, Safety / Frame, Roll Cage, Mounting Pads (Mandatory)

Mild Steel and designed to reinforce floor pan.

## General Reg 1470, Safety / Frame, Roll Cage, Mounting Plates (Mandatory)

Plates fully welded to the tubing perimeter by a fillet weld of at least 3mm.

## General Reg 1480, Safety / Frame, Roll Cage, Mounting Plates (Mandatory)

Floor mounts to fully welded to floor with a min 3mm fillet weld.

## General Reg 1490, Safety / Frame, Roll Cage, Mounting Plates (Mandatory)

At least 3mm thick.

### Four-point and Six-point Welded Roll Cage Material Selection Chart

	CM4130 Chrome Moly	CDS / CDW Mild Steel	
	Inch	Inch	mm
A	1 5/8" X 0.083"	1 5/8" x 0.120"	41.3 x 3.0 mm
		1 3/4" x 0.102"	44.45 x 2.6 mm
B1	1 5/8" X 0.083"	1 5/8" x 0.120"	41.3 x 3.0 mm
B2	1 3/8" X 0.049"	1 1/2" x 0.102"	38.1 x 2.6 mm
C	1 1/2" X 0.065"	1 1/2" x 0.102"	41.3 x 2.6 mm
			44.45 x 2.6 mm
D	1 5/8" X 0.083" (removable)	1 1/2" x 0.102"	41.3 x 2.6 mm
	1 1/2" X 0.065" (welded)		44.45 x 2.6 mm
E	1 5/8" X 0.083"	1 5/8" x 0.120"	41.3 x 2.6 mm
		1 3/4" x 0.102"	44.45 x 2.6 mm
F	1 5/8" X 0.083"	1 5/8" x 0.120"	41.3 x 2.6 mm
		1 3/4" x 0.102"	44.45 x 2.6 mm
G	1" x 0.049"	1 1/4" x 0.102"	33.7 x 2.6 mm



# SINGLE ROLL OVER HOOP

Chrome Moly

## Single Roll Over Hoop of welded construction

Vehicles that require a single roll over hoop covering the full width of the driver's compartment with two back stays, a side intrusion bar, and taxi bar.

Bolted connections must use a minimum of Grade 8 or equivalent fasteners.

### UNMODIFIED CARS with ET 10.00 - 10.50

\* Unmodified construction with fixed steel roof, slower than 10.00 seconds 1/4 mile or equivalent but faster than 10.50 seconds or equivalent.

### MODIFIED CARS with ET 11.00 - 11.99

\* Modified structural construction (not including wheel tubing) slower than 10.50 seconds 1/4 mile or equivalent, But faster than 11.99 seconds 1/4 mile or equivalent

### STREET OPEN CARS with ET 10.50 - 12.99

\* Street registered open cars Slower than 10.50 seconds 1/4 mile or equivalent

## WELDED

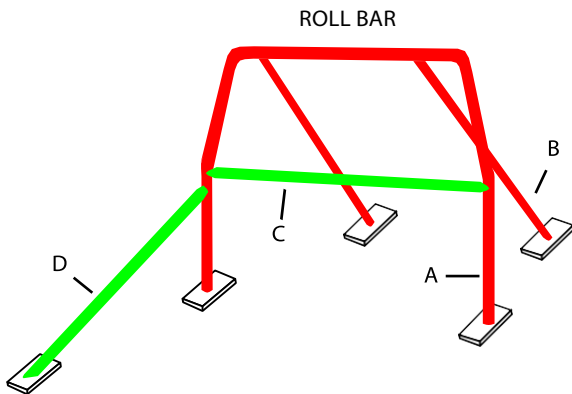

- A = Main Hoop
- B = Rear Stays
- C = Taxi Bar
- D = Intrusion Bars

## REMOVABLE Side Intrusion

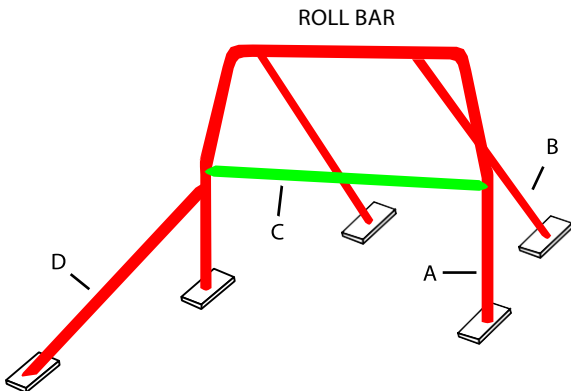

- A = Main Hoop
- B = Rear Stays
- C = Taxi Bar
- D = Intrusion Bars (Removable)

- 1 5/8 x .083
- 1 1/2 x .065



# SINGLE ROLL OVER HOOP

CDW OR CDS  
Mild Steel

## Single Roll Over Hoop of welded construction

Vehicles that require a single roll over hoop covering the full width of the drivers compartment with two back stays, a side intrusion bar and taxi bar.  
Bolted connections must use a minimum of Grade 8 or equivalent fasteners.

### UNMODIFIED CARS with ET 10.00 - 10.50

\* Unmodified construction with fixed steel roof, slower than 10.00 seconds 1/4 mile or equivalent but faster than 10.50 seconds or equivalent.

### MODIFIED CARS with ET 11.00 - 11.99

\* Modified structural construction (not including wheel tubbing) slower than 10.50 seconds 1/4 mile or equivalent, But faster than 11.99 seconds 1/4 mile or equivalent

### STREET OPEN CARS with ET 10.50 - 12.99

\* Street registered open cars Slower than 10.50 seconds 1/4 mile or equivalent

## WELDED

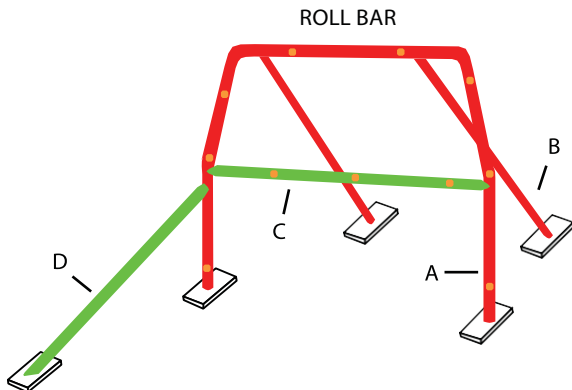

- or ■ A = Main Hoop
- B = Rear Stays
- or ■ C = Taxi Bar
- D = Intrusion Bars

	Inch	mm
■	1 5/8 x 0.120"	41.3 x 3.0
●	1 3/4 x 0.102"	44.45 x 2.6
■	1 1/2 x 0.102"	38.1 x 2.6

## REMOVABLE Side Intrusion

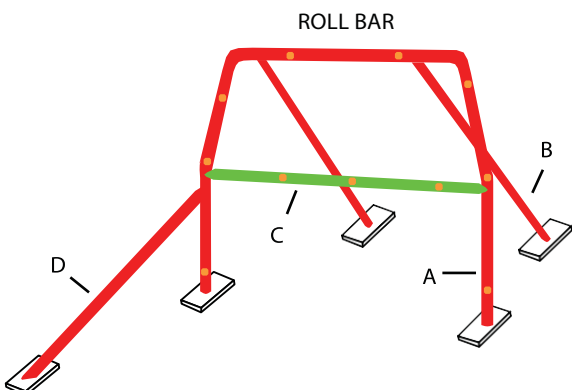

- or ■ A = Main Hoop
- B = Rear Stays
- or ■ C = Taxi Bar
- D = Intrusion Bars (Removable)

	Inch	mm
■	1 5/8 x 0.120"	41.3 x 3.0
● or ■	1 3/4 x 0.102"	44.45 x 2.6
■	1 1/2 x 0.102"	38.1 x 2.6





# FOUR POINT ROLL CAGE

Chrome Moly

Utilities may use a four-point welded roll cage design with removable side intrusion bars. Diagonal roof braces are mandatory on both sides of vehicle. Construction of four-point cages is to be based on design specifications equivalent to a six-point roll cage.

**NOTE:** All Utilities (ET 8.00 seconds 1/4 mile or slower)

Removable four-point roll cage will be built to material specifications listed below for four-point and six-point roll cage. Removable roll cage will be constructed to removable roll cage specification. Welded four-point roll cage, will be built to material specification listed for full six-point roll cage.

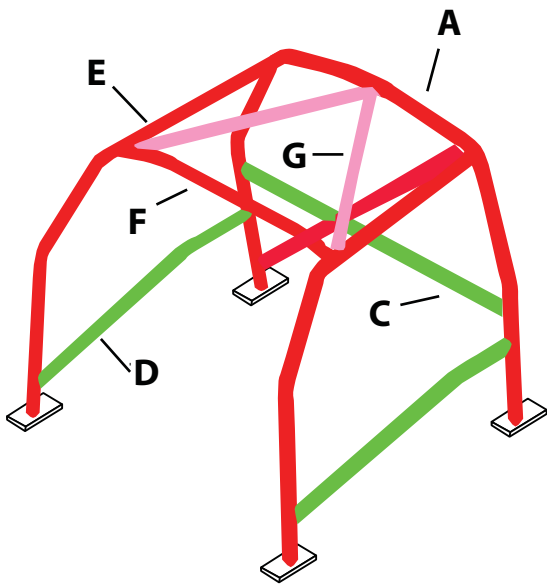

## WELDED

- or ■ A = Main Hoop
- B = Diagonal Brace
- or ■ C = Taxi Bar
- D = Intrusion Bars
- E = Forward Supports
- F = Roof Support
- G = Diagonal Roof Brace

- 1 5/8 x .083
- 1 1/2 x .065
- 1 x .049

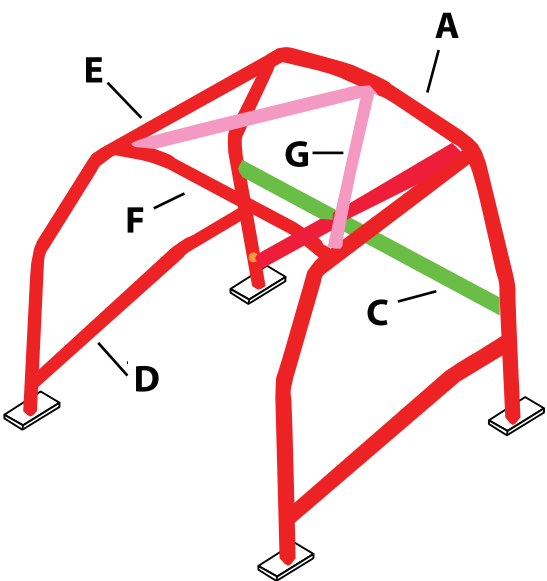

## REMOVABLE Side Intrusion

- or ■ A = Main Hoop
- B = Diagonal Brace
- or ■ C = Taxi Bar
- D = Intrusion Bars (Removable)
- E = Forward Supports
- F = Roof Support
- G = Diagonal Roof Brace

- 1 5/8 x .083
- 1 1/2 x .065
- 1 x .049



# FOUR POINT ROLL CAGE

CDW OR CDS

Mild Steel

Utilities may use a four-point welded roll cage design with removable side intrusion bars. Diagonal roof braces are mandatory on both sides of vehicle. Construction of four-point cages is to be based on design specifications equivalent to a six-point roll cage.

**NOTE:** All Utilities (ET 8.00 seconds 1/4 mile or slower)

Removable four-point roll cage will be built to material specifications listed below for four-point and six-point roll cage. Removable roll cage will be constructed to removable roll cage specification. Welded four-point roll cage, will be built to material specification listed for full six-point roll cage.

## WELDED

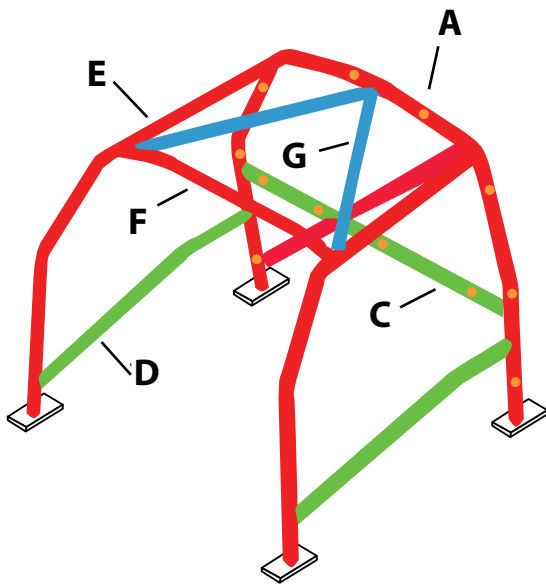

- or ■ A = Main Hoop
- B = Diagonal Brace
- or ■ C = Taxi Bar
- D = Intrusion Bars
- E = Forward Supports
- F = Roof Support
- G = Diagonal Roof Brace

	Inch	mm
■	1 5/8 x 0.120"	41.3 x 3.0
● or ■	1 3/4 x 0.102"	44.45 x 2.6
■	1 1/2 x 0.102"	38.1 x 2.6
■	1 1/4 x 0.102"	33.7 x 2.6

## REMOVABLE Side Intrusion

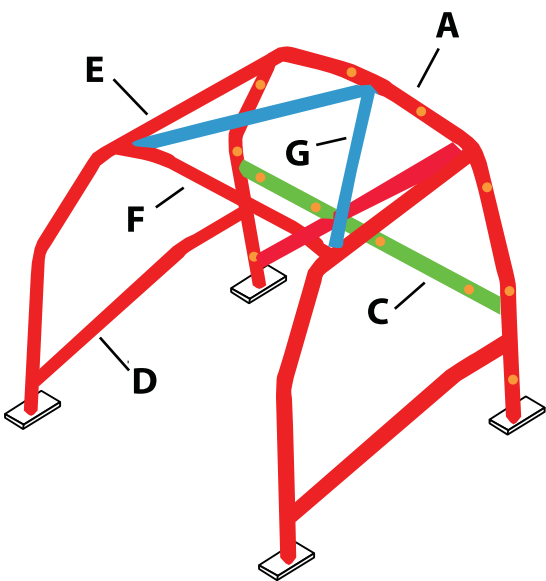

- or ■ A = Main Hoop
- B = Diagonal Brace
- or ■ C = Taxi Bar
- D = Intrusion Bars (Removable)
- E = Forward Supports
- F = Roof Support
- G = Diagonal Roof Brace

	Inch	mm
■	1 5/8 x 0.120"	41.3 x 3.0
● or ■	1 3/4 x 0.102"	44.45 x 2.6
■	1 1/2 x 0.102"	38.1 x 2.6
■	1 1/4 x 0.102"	33.7 x 2.6



# SIX POINT ROLL CAGE

Chrome Moly

## Full Six-Point Roll Cage of welded construction

Sedans, and sedan-type vehicles with an ET quicker than 10.00 seconds 1/4 mile (or 1/8 mile equivalent) require a six-point roll cage permanently welded to the vehicle frame with either welded or removable side intrusion bars.

**NOTE:** Sedan-type vehicles that are constructed in such a way that the body could separate from the chassis/roll cage in an accident, require mesh or net (with a maximum of 3 inch (75mm) openings) to be fitted to the roll cage over the drivers head.

### WELDED

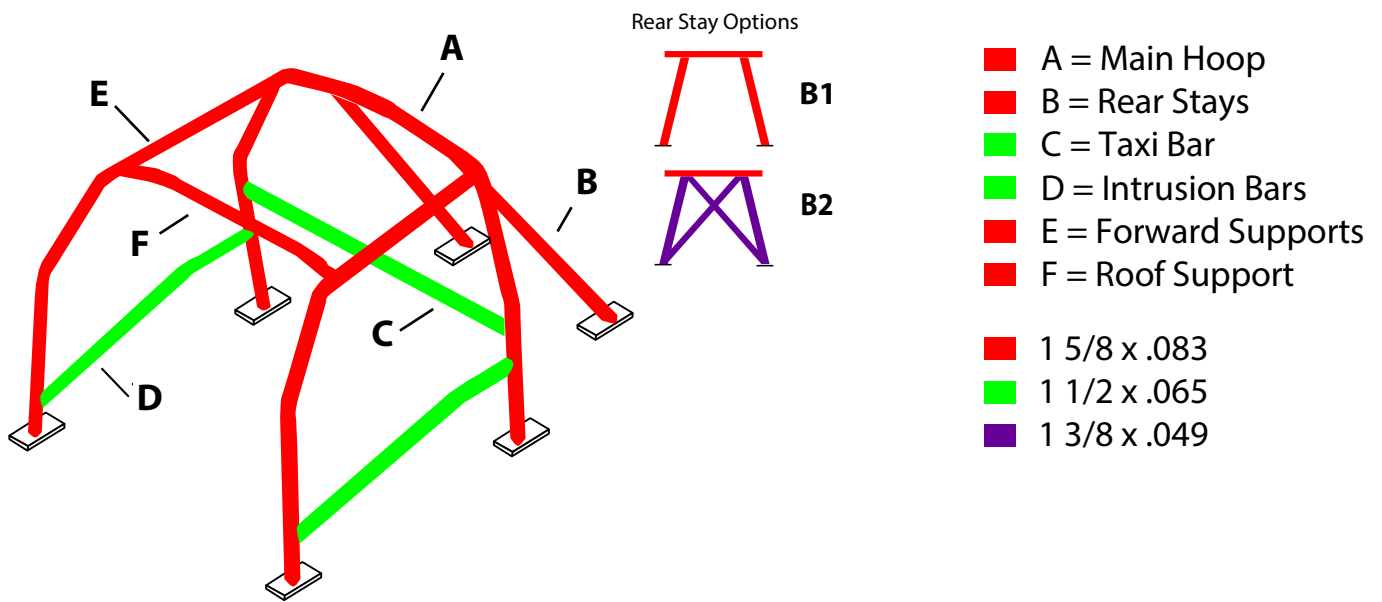

### REMOVABLE Side Intrusion

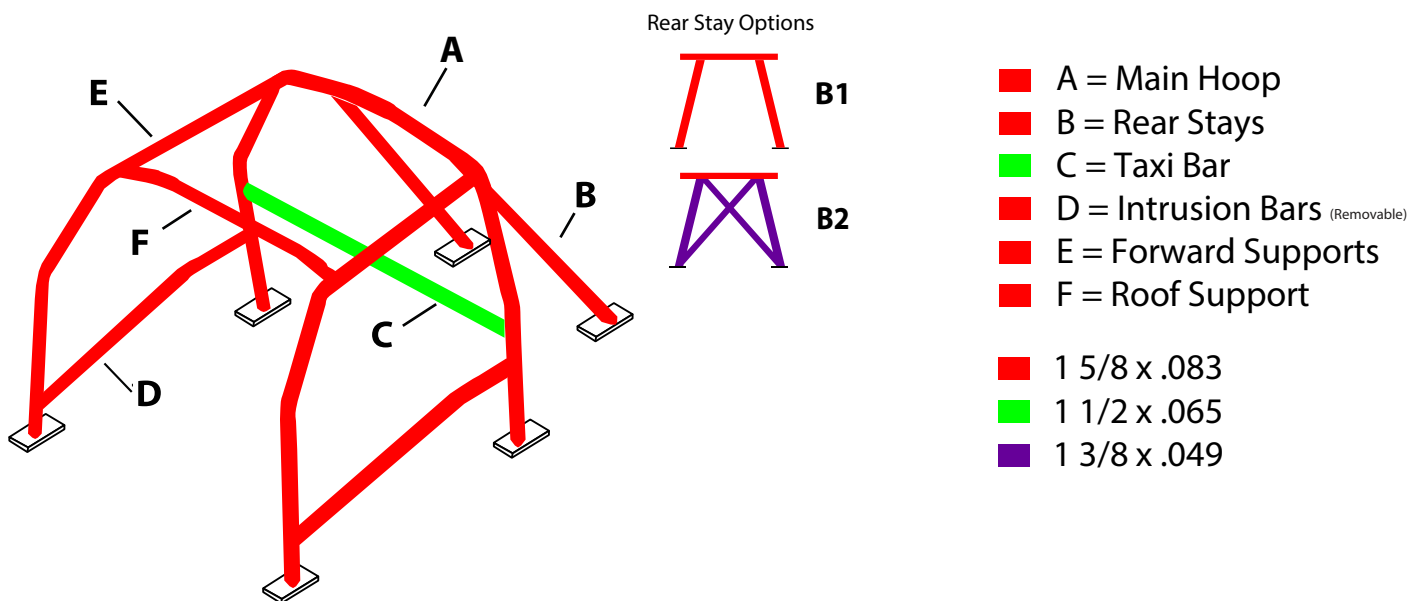



# SIX POINT ROLL CAGE

CDW OR CDS  
Mild Steel

## Full Six-Point Roll Cage of welded construction

Sedans, and sedan-type vehicles with an ET quicker than 10.00 seconds 1/4 mile (or 1/8 mile equivalent) require a six-point roll cage permanently welded to the vehicle frame with either welded or removable side intrusion bars.

**NOTE:** Sedan-type vehicles that are constructed in such a way that the body could separate from the chassis/roll cage in an accident, require mesh or net (with a maximum of 3 inch (75mm) openings) to be fitted to the roll cage over the drivers head.

### WELDED

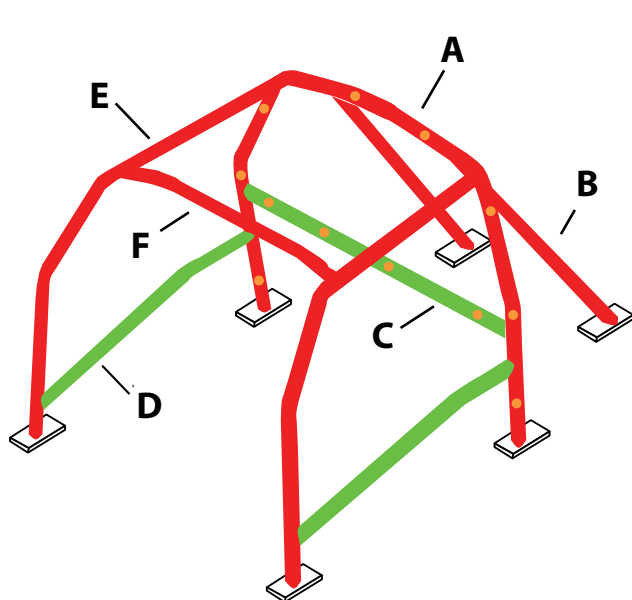

Rear Stay Options

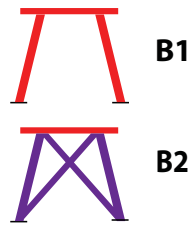

- or ■ A = Main Hoop
- or ■ B = Rear Stays
- or ■ C = Taxi Bar
- D = Intrusion Bars
- E = Forward Supports
- F = Roof Support

	Inch	mm
■	1 5/8 x 0.120"	41.3 x 3.0
● or ■	1 3/4 x 0.102"	44.45 x 2.6
■ or ■	1 1/2 x 0.102"	38.1 x 2.6

### REMOVABLE Side Intrusion

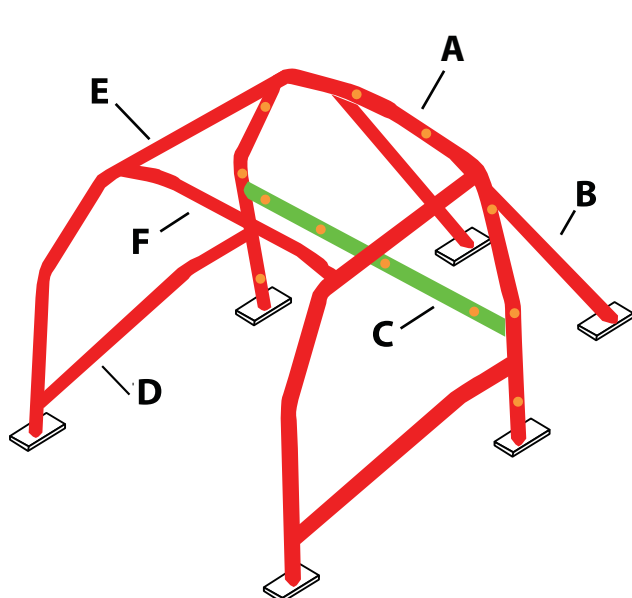

Rear Stay Options

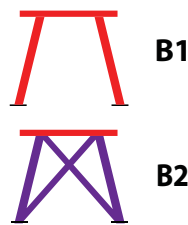

- or ■ A = Main Hoop
- or ■ B = Rear Stays
- or ■ C = Taxi Bar
- D = Intrusion Bars (Removable)
- E = Forward Supports
- F = Roof Support

	Inch	mm
■	1 5/8 x 0.120"	41.3 x 3.0
● or ■	1 3/4 x 0.102"	44.45 x 2.6
■ or ■	1 1/2 x 0.102"	38.1 x 2.6